

RULES AND REGULATIONS GOVERNING EXHIBITS

Non-Exhibiting Commercial Members

** Note changes/additions*

1. Commercial Members of OLTCA / ORCA who are not exhibiting may register for the Convention and/or Trade Show as a delegate by paying the current member delegate rate as established by the Associations.
2. Commercial Members who are **not exhibiting or sponsoring** may **not** operate individual hospitality suites. Hospitality suites include any hotel rooms where refreshments, food or entertainment are provided to delegates, unless this is a recognized sponsored event.
3. **A Commercial Member shall not be in the exhibit area to conduct any social or commercial function unless they have registered for an exhibiting booth.**

Exhibiting Commercial Members

1. All exhibit space shall conform to the specifications as outlined by OLTCA / ORCA and the exhibit site (Convention facility).
2. A company or firm must be a Commercial Member in good standing with either OLTCA and/or ORCA, in order to be an exhibitor.
3. Exhibits shall be opened and closed at the time designated by OLTCA / ORCA and no exhibitor shall remove any or all parts of the said display prior to the official closing time.
This allows 1) delegates a safe exit from the trade show floor, and 2) removal of the aisle carpeting.
4. Exhibitors may not sublet, or apportion to another party, any portion of their allotted booth.
5. Each space must be identified by the name of the exhibitor signing the contract. No other company name may appear in the booth area.
6. Draws & Lotteries are permitted, with a maximum total cumulative value of \$500 per exhibiting company.
7. Exhibitors operating games must be respectful of noise level, so not to disrupt other exhibitors conducting business.
8. Distribution of circulars or promotional material may be made only within the booth assigned to the exhibitor presenting such. Distribution of circulars at any on-site restaurants, bars, etc. is forbidden.
9. **Exhibitors may not extend exhibit activities into the aisles. This includes any direct attempt by exhibitor and/or staff to solicit and distribute material and brochures. The aisles are the property of the entire show.**
10. A Commercial Member shall not be in the exhibit area to conduct any social or commercial function unless a member has an exhibitor's booth.
11. The use of sample rooms at the Convention site for the sole purpose of displaying merchandise during the Convention by exhibitors and other supply house is forbidden.
12. Exhibitors and/or Sponsors **may not operate** individual hospitality suites or events throughout the duration of the Convention. Hospitality suites include any hotel rooms where refreshments, food or entertainment are provided to delegates.
13. No aspect of the Convention can be altered without permission from the Convention coordinator in advance of the Convention.

14. OLTC / ORCA does not provide property or liability insurance for exhibitors. Exhibitors should contact their insurer and request that their coverage be extended to insure their property and liability while they are exhibiting at the trade show.
15. OLTC / ORCA Convention Planning Committee is not responsible for lost or stolen items on the show floor.
16. Exhibitors that will be displaying large items, such as vehicles or non-conforming items should contact the Trade Show Coordinator at ORCA prior to reserving their booth location.
17. All exhibit materials and signs must be confined within the perimeter of the booth so as not to block the aisle or obstruct visibility of other exhibits. Should any concerns arise regarding the obstruction of visibility, a decision will be made by the Commercial Chairpersons.

i) Single Aisle Booths: 10' x 10'

Exhibitors' booths and material may not protrude more than 5' from the back wall of the booths above the 3' side walls. Booth signage, etc., should not be higher than the 8' backdrop.

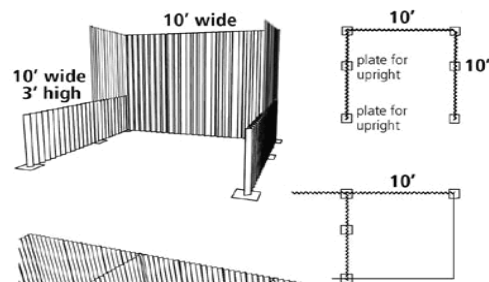

ii) Single Booth End Unit 10' x 10'

Exhibitors with a single booth at an aisle end will have a 10' back wall running north/south. Exhibitors may choose to orient their displays to face the east/west aisle, but may not exceed the 3' height beyond 5' limit from the back wall.

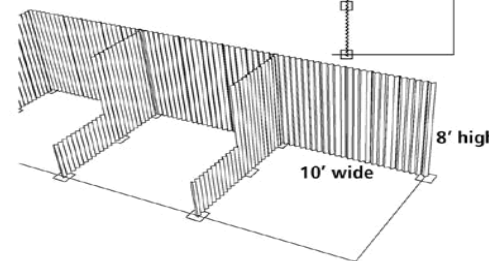

iii) Double Booth End Units Backing onto Two Aisles: 10' x 20'

Exhibitors with a double booth at end aisles will have a back wall of only 20' wide, of which 10' is only 8' high, and 5' on either side is only 3' high.

Exhibitors' booths and material may not protrude more than 5' high on either back opening above the 3' back walls and 5' extending from the back wall above the 3' side walls.

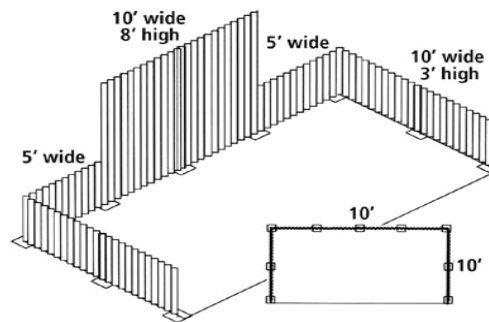

Back wall and side walls are of flame-proof pleated drapes. Uprights are bright aluminium tubing.

FAILURE TO ABIDE BY ANY OF THE ABOVE RULES MAY RESULT IN DISCIPLINARY ACTION, UP TO AND INCLUDING, REVOKING MEMBERSHIP.

THE CONVENTION PLANNING COMMITTEE RESERVES THE RIGHT TO SHUT DOWN THE EXHIBITORS' SPACE, WITHOUT ANY REFUND OF EXHIBITOR FEES.